

Tunnel-quick coupler A-Lock TU

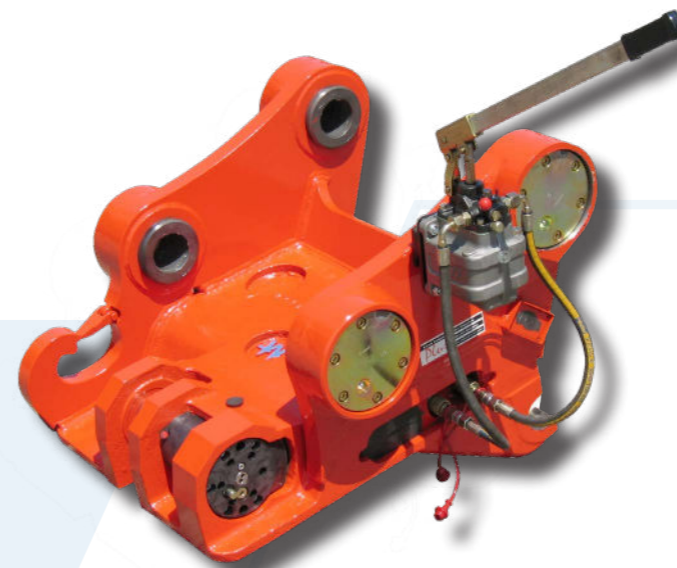

Quick coupler **A-Lock 3 Combi TU**



A-Lock 3 attachment-connection with **spring bracket**, wear compensation

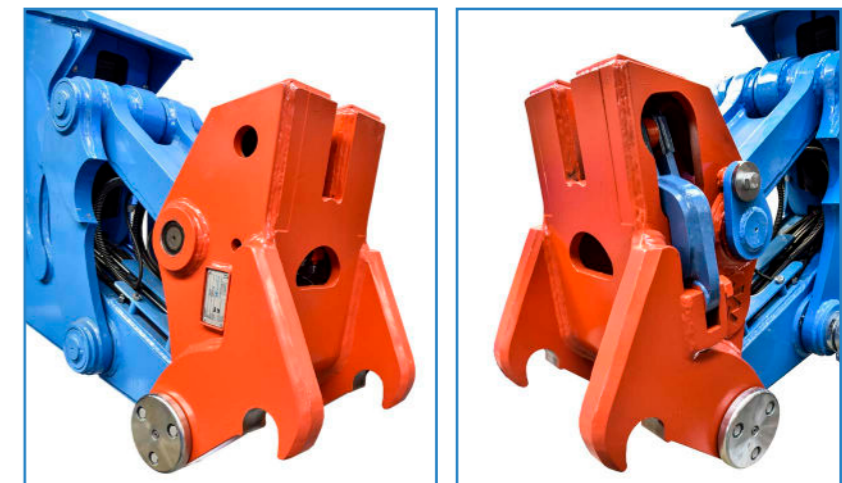

Quick coupler **A-Lock BB**

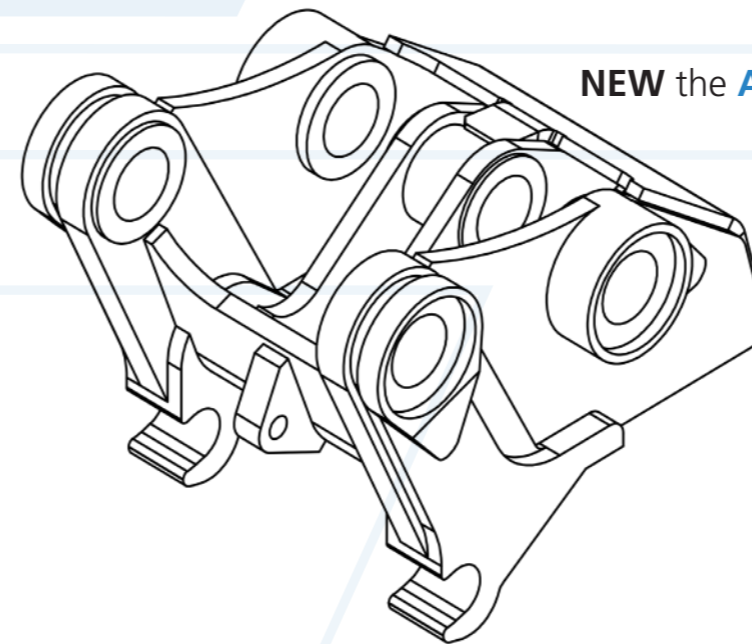

NEW the **A-Lock T5**

Weblink
A-Lock

- Highest safety standard, SUVA type approval
- For all tunnel excavator sizes
- Form-fitting locking
- Compliance with the original kinematics, no loss of power

Technical details (Subject to change)

Model	A-Lock BB	A-Lock 3 TU	A-Lock 3 Combi TU	A-Lock T-5
suitable for, examples	Blue Badger, mini Badger	yellow Fox, ECR145T, ITC312	LH R924, R930, R944 ECR235T	LH R950T, ECR355T
Excavator weight class, to.	< 12	12 - 24	24 - 40	> 40
Sealed excavator-connection possible	✓	✓	✓	✓
Number of claws	2	2	4	2
Locking version, standard	Safety	Compact / Bolt-cylinder	Compact / Bolt-cylinder	Safety
Operation by hand pump, option	✓	✓	✓	-
Mechanich version, option	-	✓	-	-
Integrated load hook	-	✓	✓	-
Load eye for shackle, option	✓	-	-	✓
Rotation circuit connections integrated	-	✓	✓	-
Improved power transmission through separate pressure piece (bucket cylinder)	✓	✓ YF	-	✓

suva

CERTIFICATION

Your advantage and highest safety standards

- ✓ **SUVA-type examination certificate Nr. E 7264**
- ✓ **Form-fitting locking, no force-locking wedge connection**
- ✓ **Compact design**
- ✓ **Two-hand operation, acoustic und optical locking control**
- ✓ **Wear compensation** according to **spring bracket** on the **tool**
- ✓ **Long service life due to;**
 - Use of **wear-resistant special steels**
 - Use of **original WIMMER** attachment tools
 - **Professional regeneration** of the **quick coupler** by **WIMMER**
 - **Regeneration** of the **attachments simultaneously** with the **quick coupler regeneration**

WIMMER Hartstahl GmbH & Co KG und WIMMER Felstechnik GmbH
Industriestraße 3 | A-5303 Thalgau, AUSTRIA | Tel. +43 (0)6235 6655-0

All Rights and technical changes reserved. Copyrighted. Record and printing errors reserved. Status 10/25

