

## Tunnel-attachment-tools

- Attachments for all common tunnel excavators
- Project-related special solutions **Weblink Tunneling**
- Hammer, Cutter, Bucket, Tunnel-grapple, Shears

## Tunnel-quick coupler A-Lock

- For tunnel excavators from 12 to 50 to.
- Highest safety standard **Weblink A-Lock**
- SUVA certified

## mini Badger | mini e-Bdager

- For tunnel heights from 2,7 m
- Engine power: Diesel 53,7 kW | E-Motor 50 kW
- Operating weight: 11,5 to

**Weblink mini Badger**

**Weblink mini e-Bdager**

## Yellow Fox

- For tunnel heights from 4,2 m
- Engine power: Diesel 90 kW
- Operating weight: 22 to

**Weblink Yellow Fox**

## Blue Badger | e-Bdager

- For tunnel heights from 3,5 m
- Engine power: Diesel 53,7 kW | E-Motor 50 kW
- Operating weight: 12,8 to

**Weblink Blue Badger**

**Weblink e-Bdager**

# Tunnel excavator Blue Badger | e-Badger

- For tunnel cross-sections from Ø 3,5 m
- High breakout forces for the tunnel excavate
- Equipment specially developed for tunneling
- Precisely designed for the tunnel construction

Weblink  
Blue Badger

Weblink  
e-Badger

Digging arc	
Tunnel height [m]	Feed [mm]
3,5	2.220
4	2.403
4,5	2.366
5	2.255
5,5	2.212



Hydraulic cutter with the e-Badger

# Tunnel-attachment-tools fitting on Blue Badger | e-Badger



## Tunnel driving bucket LPT460



**Teeth:** 2x ESCO U30 P  
**Cutting width:** 460 mm  
**Connection:** A-Lock BB

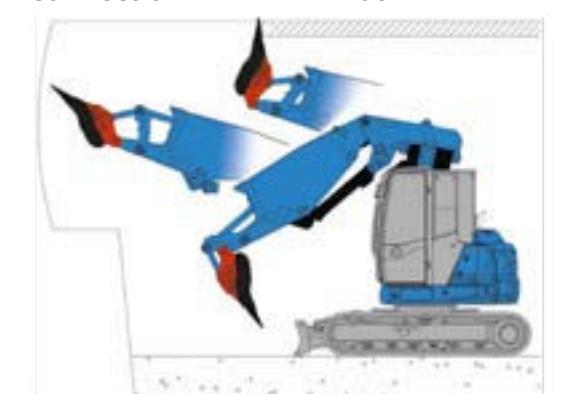

**Standard-form** suitable for tunneling and for overhead follow-up work

## Bucket LP800FG2.5



**Teeth:** 5x ESCO U20 S  
**Cutting width:** 800 mm  
**Capacity:** 367 l/SAE  
**Connection:** A-Lock BB

## Hydraulic breaker WH10 TU/UW



✓ **Tunnel-version (TU):** Special tunnel sealing for the chisel | High-speed-piston with a shortened stroke for additional protection

✓ **Underwater-version (UW\*\*):** Prepared with a separate connection for the air supply in the area of the bushings and the piston

✓ **Combination with TU & UW\*\*:** Additional protection against the ingress of water, dirt, and dust | Long service life \*\* An external air supply is required

**Operating weight:** 750 kg (ohne Adapter)  
**Oil flow:** 60 - 120 L/min  
**Working pressure:** 125 bar  
**Pressure relief valve:** 160 bar  
**Chisel Ø :** 95 mm  
**Drilling pattern :** WH10/12



The NEW tunnel sealing

## Hydraulic cutter Rockwheel



Cutter D10 (Compact)

**Hydraulic power:** 29 kW  
**Max. oil flow:** 113 L/min  
**Optimum oil flow:** 60 L/min

**Torque of cutter:** 4.174 Nm @ 350bar  
**Drum speed:** 80 rpm @ 120 L/min

**Operating weight:** 462 kg (without adapter)  
**Number of chisel:** 56 pc.

**Application:** Profiling, Tunnel drive

## Cutter D15 (Performance)

**Hydraulic power:** 41 kW  
**Max. oil flow:** 132 L/min  
**Optimum oil flow:** 120 L/min

**Torque of cutter:** 6.945 Nm @ 350bar  
**Drum speed:** 96,2 rpm @ 120 L/min

**Operating weight:** 595 kg (without adapter)  
**Number of chisel:** 65 pc.

**Application:** Tunnel drive, Mining

**Option:** Cutter D10 or D15 with 360° rotator

**Endlessly rotatable** in according to a integrated rotary union  
Optionally, all types are also available with a **water spray unit** for dust suppression

## Demolition shear Tunn-Cut 500 H



**Weight** without adapter: 1.340 kg  
**Max. opening width:** 520 mm  
**Excavator weight:** from 12 to.

**Hydraulic data:**

**Rotation pressure:** max. 200bar  
**Rotation oil flow:** 20-25 L/min  
**Open/close pressure:** max. 350 bar  
**Open/close oil flow:** max. 200 L/min

## DARDA CC700

**Weight** without adapter: 700 kg  
**Max. opening width:** 650 mm  
**Excavator weight:** 7 - 15 to.

**Hydraulic data:**

**Rotation pressure:** max. 200bar  
**Rotation oil flow:** 20-25 L/min  
**Open/close pressure:** max. 270 bar  
**Open/close oil flow:** max. 150 L/min

## Lattice arch gripper GBG-180



Custom-made **tunnel arch gripper** specifically designed for the safe installation of **tunnel arches**

**Tilting function:** 2 x 45°

**Drilling pattern:** WH17/22, WH10/12 or ALBB - direct

**Interchangeable gripping units:**

Possible **3-belt H1 arches:** 70, 95, 115  
Possible **4-belt H1 arches:** 190

**Hydraulic data:**

**Max. pressure:** max. 200bar  
**Max. oil flow:** 20-25 L/min

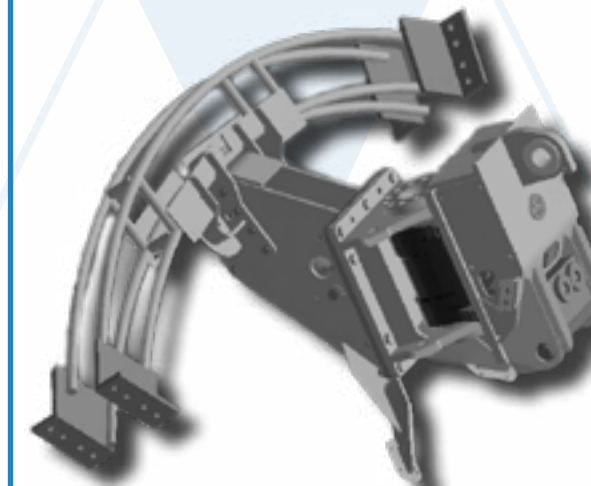

## Digging arc - schema Blue-/e-Badger

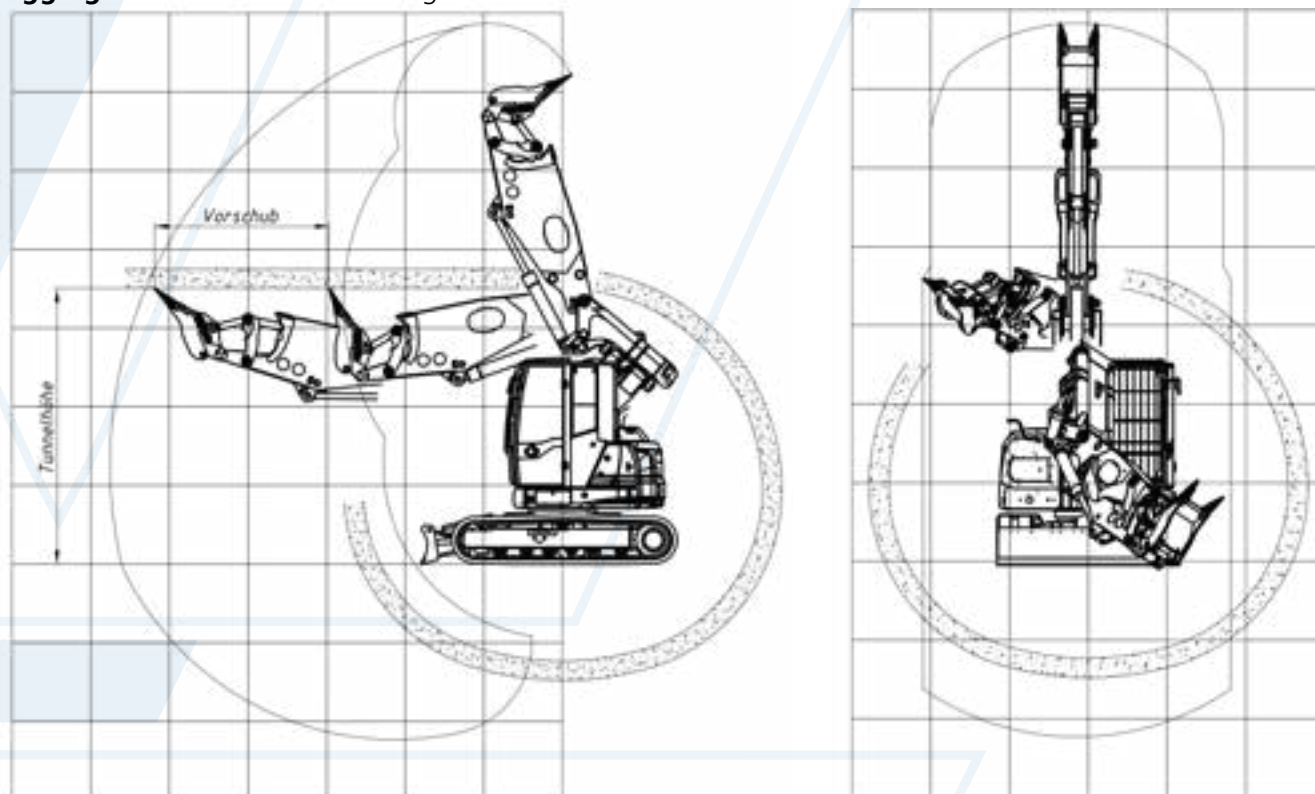

## Dimensions - transport Blue-/e-Badger

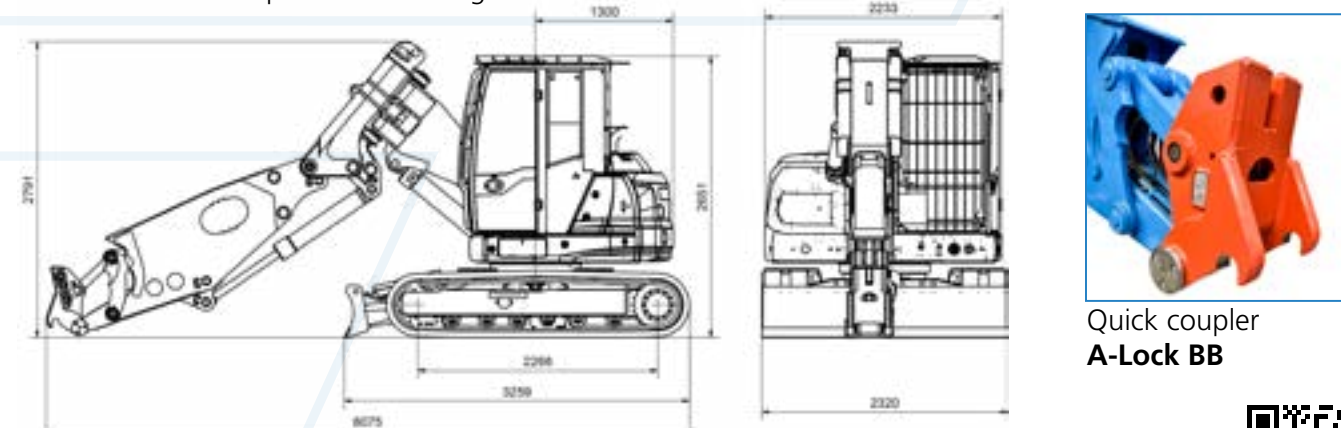

Quick coupler A-Lock BB

operation video >>>



wimmer.info

## Technical details (Subject to change)

Model	Blue Badger	e-Badger
Operating weight, kg	12.800	12.700
Engine power, kW	53,7	50
Tunnel height minimum, m	3,5	3,5
Tunnel width minimum, m	2,5	2,5
Tunnel width min. - 180° Rotate uppercarriage, m	4,2	4,2
Standard quick coupler	A-Lock BB	A-Lock BB
Breakout force, kN	85	85
Tear force, kN	100	100
Control voltage, V	12 DC	12/24 DC
Central greasing unit	✓	✓
<b>Engine model</b>		
Engine type	Yanmar Turbo Diesel Stage 5 / Tier 4 Final	Synchronous reluctance motor (SRPM)
Exhaust aftertreatment	Particular filter (DPF)	-
Fuel content   E-connection	105 L	400VAC 50 Hz - 125A
Consumption, Ø	9,3 l/h	45 kW/h
Cooling	Water cooling	Water cooling
<b>Safety features - standard</b>		
Quick coupler A-Lock with SUVA-certification	✓	✓
Automatic fire extinguishing system	✓	✓
Emergency stop button and reversing alarm device	✓	✓
Rear view and side view camera	✓	✓
Stop valves on all cylinders	✓	✓
Cabin with ROPS and FOPS Stage II	✓	✓
Closed cabin with sound reduction**	✓	✓
<b>Hydraulic system</b>		
Tank capacity	90 L	90 L
System capacity	120 L	120 L
Hammer-/ shear circuit	max. 130 L/min, max. 290bar	max. 130 L/min, max. 290bar
Grapple-rotation circuit	max. 20 L/min, max. 200bar	max. 20 L/min, max. 200bar
Hydraulic system - type	Axial piston pump with LS, Hyd.-pilot control	Axial piston pump with LS, Hyd.-pilot control
Separate tank line with return filter	✓	✓
Separate leakage oil line with leakage oil filter	✓	✓
<b>Possible Attachments</b>		
Tunnel driving bucket, loading bucket	Tunnel-bucket 460, bucket 800FG2.5	Tunnel-bucket 460, bucket 800FG2.5
Hydraulic breaker	WH10 TU/UW	WH10 TU/UW
Hydraulic cutter	WR15, WFR150, D15	WR15, WFR150, D15
Drilling attachment	AB1300, AB2300-BB, WIDA	AB1300, AB2300-BB, WIDA
Demolition shear	TunnCut 500	TunnCut 500
Tunnel gripper	Lattice arch gripper GBG-180	Lattice arch gripper GBG-180

## Option for e-Badger

- Battery-Pack for transfer trips
- Voltage 691 V (nominal)
- Gross capacity 52 kWh

WIMMER Hartstahl GmbH & Co KG und WIMMER Felstechnik GmbH  
Industriestraße 3 | A-5303 Thalgau, AUSTRIA | Tel. +43 (0)6235 6655-0

All rights and technical changes reserved. Copyrighted. Record and printing errors reserved. Status 2/26



>>> back to the general overview

wimmer.info

\*\* according to 2000/14/EC as amended LWA dB(A) 99

# Tunnel excavator mini Badger | mini e-Badger

- For tunnel cross-sections from Ø 2,7 m
- All functions radio remote controlled
- Equipment specially developed for tunneling
- Precisely designed for the tunnel construction

Weblink  
mini Badger

Weblink  
mini e-Badger

Digging arc	
Tunnel height [m]	Feed [mm]
2,7	1.460
3,5	1.750
4	1.690
4,5	850



E-connection mini e-Badger

## Technical details (Subject to change)

Model	mini Badger	mini e-Badger
Operating weight, kg	11.500	11.200
Engine power, kW	53,7	50
Tunnel height minimum, m	2,7	2,7
Tunnel width minimum, m	2,5	2,5
Tunnel width min. - 180° Rotate uppercarriage, m	3,3	3,3
Standard quick coupler	A-Lock BB	A-Lock BB
Breakout force, kN	85	85
Tear force, kN	110	110
Control voltage, V	12 DC	24 DC
Central greasing unit	✓	✓
Radio remote control of the entire machine	✓	✓
<b>Engine model</b>		
Engine type	Yanmar Turbo Diesel Stage 5 / Tier 4 Final	Synchron-Reluktanzmotor (SRPM)
Exhaust aftertreatment	Partikelfilter (DPF)	-
Fuel content   E-connection	105 L	400VAC 50 Hz -125A
Consumption, Ø	9,3 l/h	45 kW/h
Cooling	Water cooling	Water cooling
<b>Safety features - standard</b>		
Quick coupler A-Lock with SUVA-certification	✓	✓
Automatic fire extinguishing system	✓	✓
Emergency stop button and reversing alarm device	✓	✓
Stop valves on all cylinders	✓	✓
<b>Hydraulic system</b>		
Tank capacity	90 L	90 L
System capacity	120 L	120 L
Hammer-/ shear circuit	max. 130 L/min, max. 290bar	max. 130 L/min, max. 290bar
Grapple-rotation circuit	max. 20 L/min, max. 200bar	max. 20 L/min, max. 200bar
Hydraulic system - type	Axial piston pump with LS, Hyd.-pilot control	Axial piston pump with LS, Hyd.-pilot control
Separate tank line with return filter	✓	✓
Separate leakage oil line with leakage oil filter	✓	✓
<b>Possible Attachments</b>		
Tunnel driving bucket, loading bucket	Tunnel-bucket 460, bucket 800FG2.5	Tunnel-bucket 460, bucket 800FG2.5
Hydraulic breaker	WH10 TU/UW	WH10 TU/UW
Hydraulic cutter	WR15, WFR150, D15	WR15, WFR150, D15
Drilling attachment	AB1300, AB2300-BB, WIDA	AB1300, AB2300-BB, WIDA
Demolition shear	TunnCut 500	TunnCut 500
Tunnel gripper	Lattice arch gripper GBG-180	Lattice arch gripper GBG-180

Digging arc - schema mini-/e-Badger

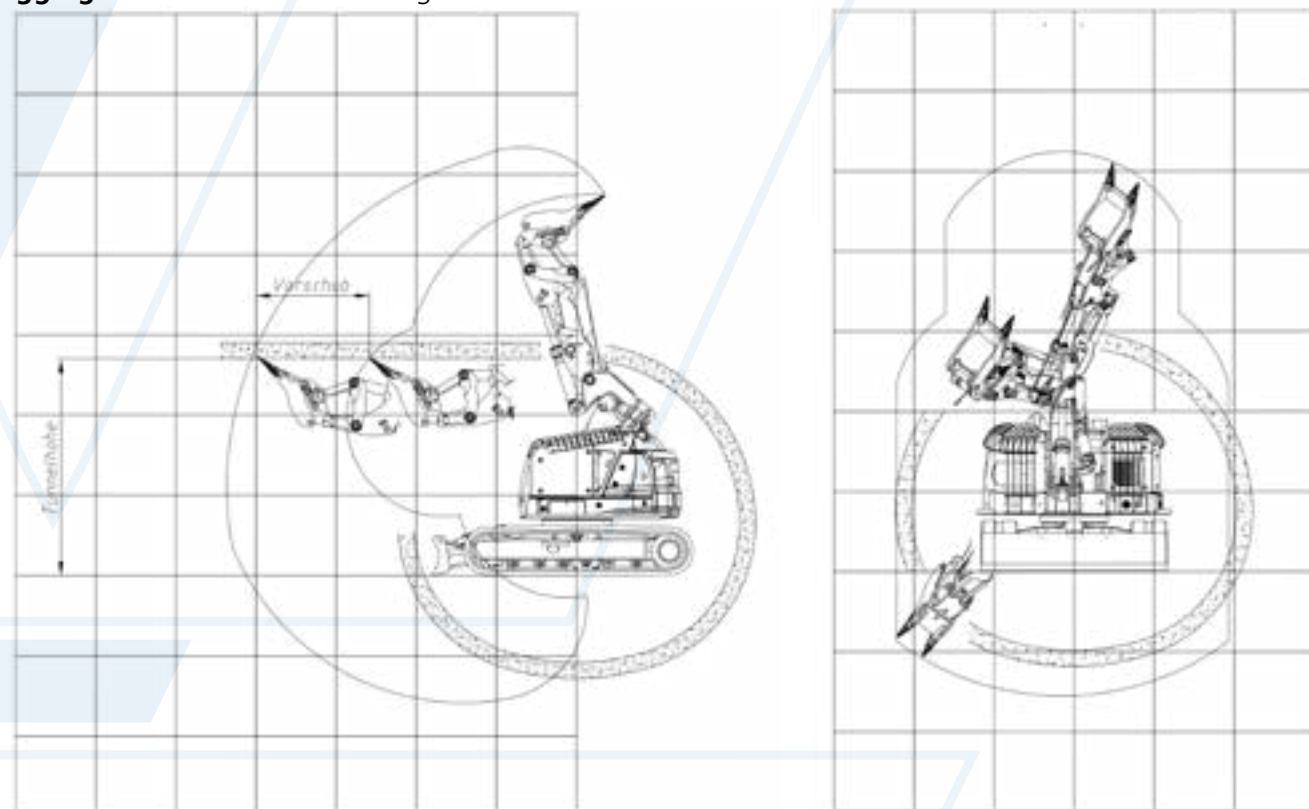

Dimensions - loading mini-/e-Badger

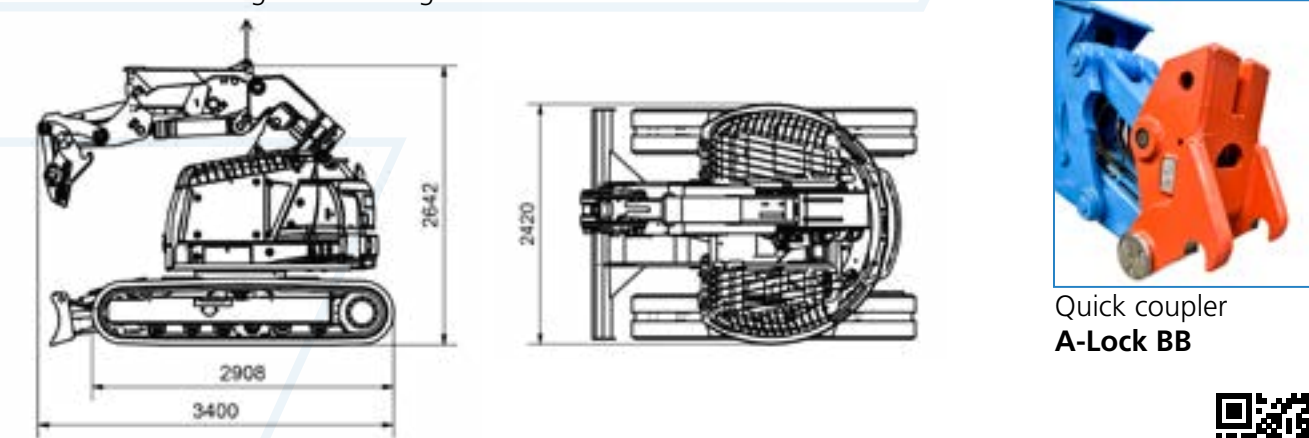

- Option for mini e-Badger**
- Battery-Pack for transfer trips
  - Voltage 691 V (nominal)
  - Gross capacity 52 kWh

operation video >>>



wimmer.info

# Tunnel-attachment-tools fitting on mini Badger | mini e-Badger



## Tunnel driving bucket LPT460



**Teeth:** 2x ESCO U30 P  
**Cutting width:** 460 mm  
**Connection:** A-Lock BB

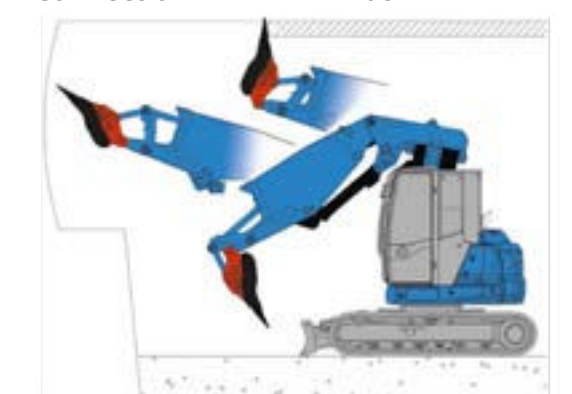

**Standard-form** suitable for tunneling and for overhead follow-up work

## Bucket LP800FG2.5



**Teeth:** 5x ESCO U20 S  
**Cutting width:** 800 mm  
**Capacity:** 367 l/SAE  
**Connection:** A-Lock BB

## Hydraulic breaker WH10 TU/UW



✓ **Tunnel-version (TU):** Special tunnel sealing for the chisel | High-speed-piston with a shortened stroke for additional protection

✓ **Underwater-version (UW\*\*):** Prepared with a separate connection for the air supply in the area of the bushings and the piston

✓ **Combination with TU & UW\*\*:** Additional protection against the ingress of water, dirt, and dust | Long service life \*\* An external air supply is required

**Operating weight:** 750 kg (ohne Adapter)  
**Oil flow:** 60 - 120 L/min  
**Working pressure:** 125 bar  
**Pressure relief valve:** 160 bar  
**Chisel Ø :** 95 mm  
**Drilling pattern :** WH10/12



The **NEW** tunnel sealing

## Hydraulic cutter Rockwheel Cutter D10 (Compact)



**Hydraulic power:** 29 kW  
**Max. oil flow:** 113 L/min  
**Optimum oil flow:** 60 L/min

**Torque of cutter:** 4.174 Nm @ 350bar  
**Drum speed:** 80 rpm @ 120 L/min

**Operating weight:** 462 kg (without adapter)  
**Number of chisel:** 56 pc.

**Application:** Profiling, Tunnel drive

## Cutter D15 (Performance)

**Hydraulic power:** 41 kW  
**Max. oil flow:** 132 L/min  
**Optimum oil flow:** 120 L/min

**Torque of cutter:** 6.945 Nm @ 350bar  
**Drum speed:** 96,2 rpm @ 120 L/min

**Operating weight:** 595 kg (without adapter)  
**Number of chisel:** 65 pc.

**Application:** Tunnel drive, Mining

**Option:** Cutter D10 or D15 with 360° rotator

**Endlessly rotatable** in according to a integrated rotary union  
Optionally, all types are also available with a **water spray unit** for dust suppression

## Demolition shear Tunn-Cut 500 H



**Weight** without adapter: 1.340 kg  
**Max. opening width:** 520 mm  
**Excavator weight:** from 12 to.

**Hydraulic data:**

**Rotation pressure:** max. 200bar  
**Rotation oil flow:** 20-25 L/min  
**Open/close pressure:** max. 350 bar  
**Open/close oil flow:** max. 200 L/min

## DARDA CC700

**Weight** without adapter: 700 kg  
**Max. opening width:** 650 mm  
**Excavator weight:** 7 - 15 to.

**Hydraulic data:**

**Rotation pressure:** max. 200bar  
**Rotation oil flow:** 20-25 L/min  
**Open/close pressure:** max. 270 bar  
**Open/close oil flow:** max. 150 L/min

## Lattice arch gripper GBG-180



Custom-made **tunnel arch gripper** specifically designed for the safe installation of **tunnel arches**

**Tilting function:** 2 x 45°

**Drilling pattern:** WH17/22, WH10/12 or ALBB - direct

**Interchangeable gripping units:**

Possible **3-belt H1 arches:** 70, 95, 115  
Possible **4-belt H1 arches:** 190

**Hydraulic data:**

**Max. pressure:** max. 200bar  
**Max. oil flow:** 20-25 L/min

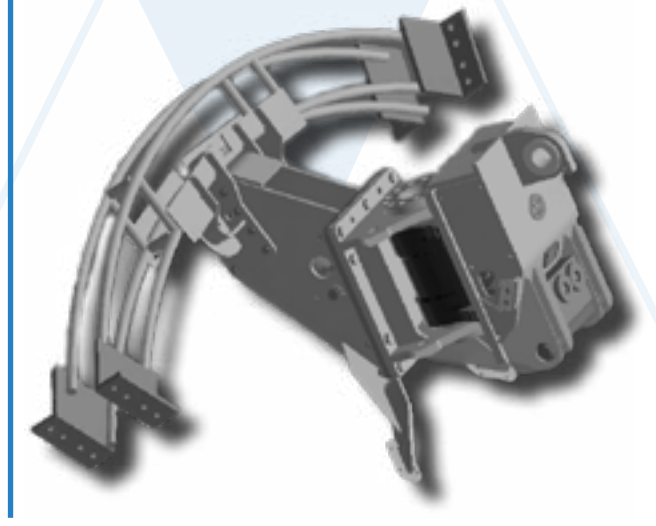

WIMMER Hartstahl GmbH & Co KG and WIMMER Felstechnik GmbH  
Industriestraße 3 | A-5303 Thalgaun, AUSTRIA | Tel. +43 (0)6235 6655-0

All rights and technical changes reserved. Copyrighted. Record and printing errors reserved. Status 2/26

>>> back to the general overview

wimmer.info

# Tunnel excavator yellow Fox

■ For tunnel cross-sections from Ø 4,2 m

■ Working height: 4,2 m - 7 m

■ Equipment specially developed for tunneling

■ Precisely designed for the tunnel construction

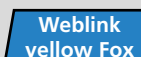

Digging arc	
Tunnel height [m]	Feed [mm]
4,2	2.340
5,0	2.750
5,5	3.050
6,0	2.960
6,5	2.930
7,0	3.020



Operation with hydraulic cutter WR18



Extinguishing container and optional Blaxtair person detection system



Central lubrication distributor



Central greasing unit



wimmer.info

# Tunnel-attachment-tools fitting on yellow Fox



## Tunnel driving bucket LPT600



**Teeth:** 2x ESCO U35 P  
**Cutting width:** 600 mm  
**Connection:** A-Lock 3

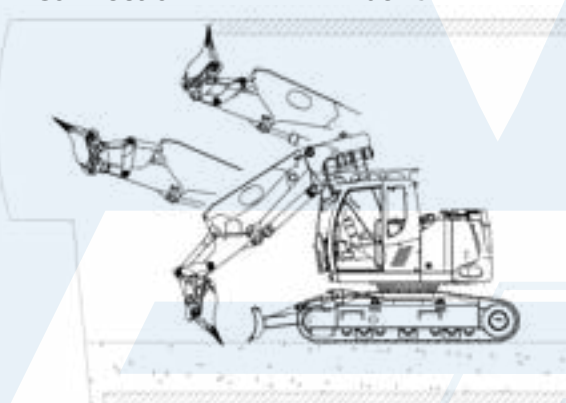

**Standard-form** suitable for tunneling and for overhead follow-up work

## Bucket LP1000FG3.3



**Teeth:** 4x ESCO U30 S  
**Cutting width:** 1.000 mm  
**Capacity:** 818 l/SAE  
**Connection:** A-Lock 3

## Hydraulic breaker WH17 TU/UW



✓ **Tunnel-version (TU):** Special tunnel sealing for the chisel | High-speed-piston with a shortened stroke for additional protection

✓ **Underwater-version (UW\*\*):** Prepared with a separate connection for the air supply in the area of the bushings and the piston

✓ **Combination with TU & UW\*\*:** Additional protection against the ingress of water, dirt, and dust | Long service life \*\* An external air supply is required

**Operating weight:** 1.100 kg (ohne Adapter)  
**Oil flow:** 70 - 130 L/min  
**Working pressure:** 135 bar  
**Pressure relief valve:** 170 bar  
**Chisel Ø :** 115 mm  
**Drilling pattern :** WH17/22



The NEW tunnel sealing

## Hydraulic cutter Rockwheel



Cutter D15 (Compact)

**Hydraulic power:** 41 kW  
**Max. oil flow:** 132 L/min  
**Optimum oil flow:** 120 L/min

**Torque of cutter:** 6.945 Nm @ 350bar  
**Drum speed:** 96,2 rpm @ 120 L/min

**Operating weight:** 595 kg (without adapter)  
**Number of chisel:** 65 pc.

**Application:** Profiling, Tunnel drive

Cutter D20 (Performance)

**Hydraulic power:** 70 kW  
**Max. oil flow:** 320 L/min  
**Optimum oil flow:** 220 L/min

**Torque of cutter:** 15.627 Nm @ 350bar  
**Drum speed:** 78,2 rpm @ 120 L/min

**Operating weight:** 1.170 kg (without adapter)  
**Number of chisel:** 64 pc.

**Application:** Tunnel drive, Mining

**Option:** Cutter D15 with 360° rotator

**Endlessly rotatable** in according to a integrated rotary union

Optionally, all types are also available with a **water spray unit** for dust suppression

## Demolition shear Top-Cut 550 Universal



**Weight** without adapter: 1.885 kg  
**Max. opening width:** 550 mm  
**Mouth depth:** 530 mm

**Jaw model:** Universal  
**Excavator weight:** ab 16 to.

**Drilling pattern:** WH17/22, or AL3

**Hydraulic data:**

**Rotation pressure:** max. 200bar  
**Rotation oil flow:** 20-25 L/min

**Open/close pressure:** max. 350 bar  
**Open/close oil flow:** max 200 L/min



## Lattice arch gripper GBG-270



Custom-made **tunnel arch gripper** specifically designed for the safe installation of **tunnel arches**

**Tilting function:** 2 x 45°  
**Connection:** AL3

**Interchangeable gripping units:**  
Possible **3-belt H1 arches:** 70, 95, 115  
Possible **4-belt H1 arches:** 190

**Hydraulic data:**

**Max. pressure:** max. 200bar  
**Max. oil flow:** 20-25 L/min

## Tunnel arch gripper WTG-270 / WTG-270-Universal



**Gripper** specifically designed for the **safe installation** of **tunnel arches**

**Tilting function:** 2 x 45°  
**Connection:** AL3

**Interchangeable gripping units - HEB (WTG-270):** HEB220, HEB240

**Interchangeable die for WTG-270-Universal:** THN21, THN29, TH70/40-44, HEB120, 140, 160, 180

**Hydraulic data:**

**Max. pressure:** max. 200bar  
**Max. oil flow:** 20-25 L/min

## Digging arc - schema yellow Fox

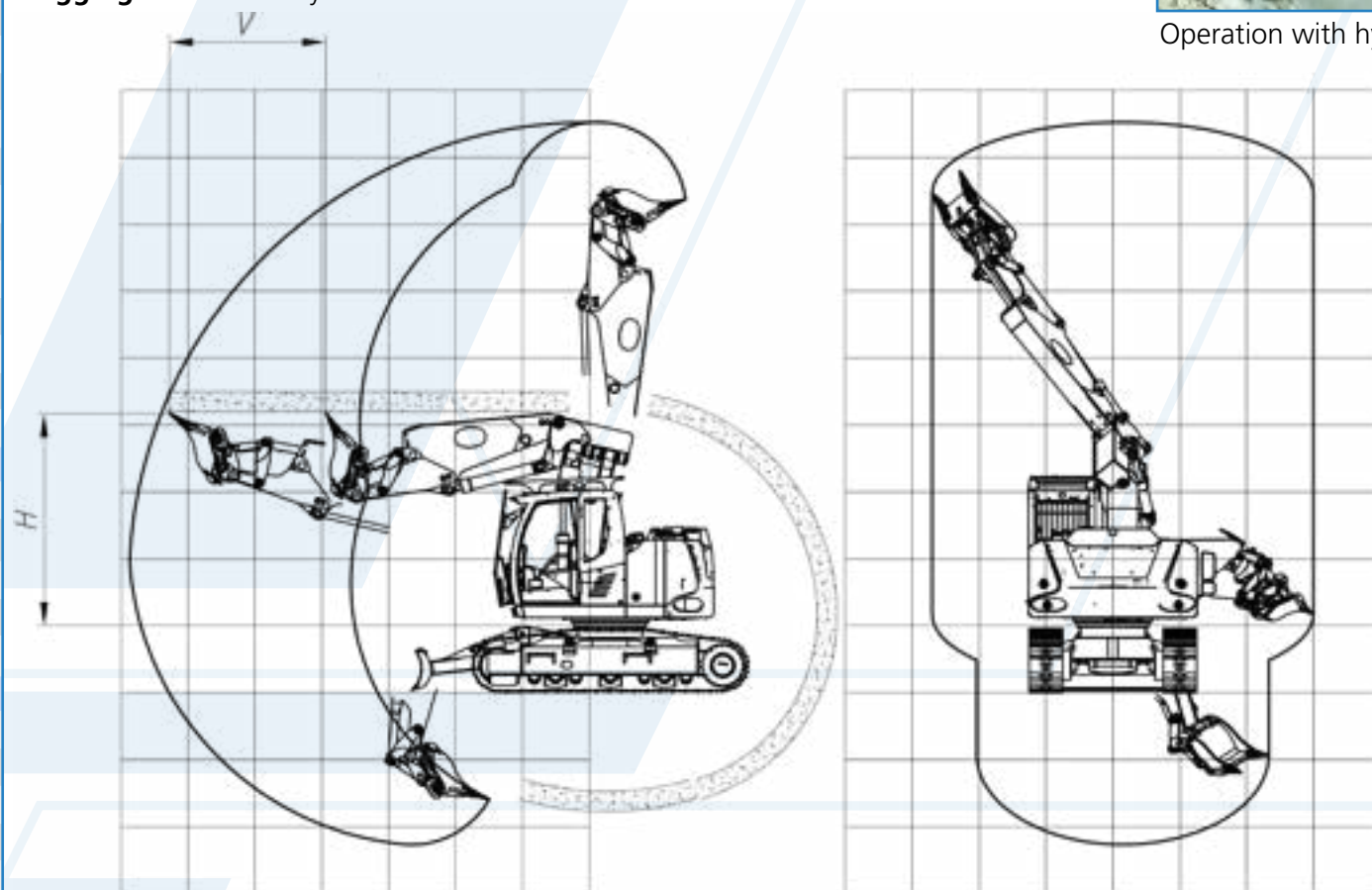

## Dimensions - transport yellow Fox

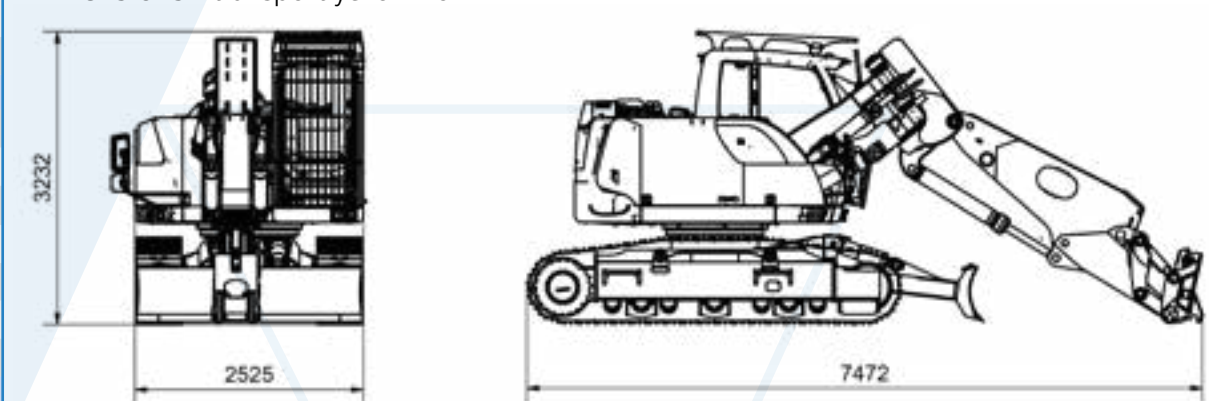

## Hydraulic oil Safetyfluid 46

- **Flame-retardant** according to DIN EN ISO 12922, flash point at 274 °C
- **Oxidation and wear resistance** - Long oil change intervals
- **No ester oil** - Hydrolytic stability and tolerance to moisture ingress
- **Biodegradability** at 80%



wimmer.info

## Technical details (Subject to change)

Model	yellow Fox
Operating weight, kg	22.000
Engine power, kW	90
Tunnel height minimum, m	4,2
Tunnel width minimum, m	3,0
Tunnel width min. - 180° Rotate uppercarriage, m	5,2
Standard quick coupler	A-Lock 3
Breakout force, kN	115
Tear force, kN	120
Control voltage, V	24 DC
Central greasing unit	✓
Uppercarriage	LH R914 Compact
Undercarriage	LH R920 - 192 kN traction
<b>Engine model</b>	
Engine type	4 Zyl. DEUTZ Common-Rail Diesel, Stage 5 / Tier 4 Final
Exhaust aftertreatment	DOC, DPF, SCR
Fuel content	175 L
Consumption, Ø	11,9 l/h
Cooling	
<b>Safety features - standard</b>	
Quick coupler A-Lock with SUVA-certification	✓
Automatic fire extinguishing system	✓
Emergency stop button and reversing alarm device	✓
Rear view and side view camera	✓
Stop valves on all cylinders	✓
Cabin with ROPS and FOPS Stage II	✓
Closed cabin with sound reduction**	✓
Flame-retardant hydraulic oil	✓ Safetyfluid 46
<b>Hydraulic system</b>	
Tank capacity	100 L
System capacity	230 L
Hammer-/ shear circuit	max. 200 L/min, max. 350 bar
Grapple-rotation circuit	max. 20 L/min, max. 200 bar
Hydraulic system - type	Axial piston pump with LSC, Hyd.-pilot control
Separate tank line with return filter	✓
Separate leakage oil line with leakage oil filter	✓
<b>Possible Attachments</b>	
Tunnel driving bucket, loading bucket	Tunnel bucket 600, Bucket 1000FG3.3
Hydraulic breaker	WH17 TU/UW
Hydraulic cutter	WR18, D20
Drilling attachment	AB2300-BB, WIDA
Demolition shear	Top-Cut 550
Tunnel gripper	WTG-270 / Universal

\*\* gemäß 2000/14/EG in der geltenden Fassung LWA dB(A) 99

WIMMER Hartstahl GmbH & Co KG und WIMMER Felstechnik GmbH  
Industriestraße 3 | A-5303 Thalgaun, AUSTRIA | Tel. +43 (0)6235 6655-0

All rights and technical changes reserved. Copyrighted. Record and printing errors reserved. Status 2/26



>>> back to the general overview

wimmer.info

# Tunnel-quick coupler A-Lock TU

- Highest safety standard, SUVA type approval
- For all tunnel excavator sizes
- Form-fitting locking
- Compliance with the original kinematics, no loss of power

Weblink  
A-Lock



Quick coupler **A-Lock 3 Combi TU**



**A-Lock 3** attachment-connection with **spring bracket**, wear compensation

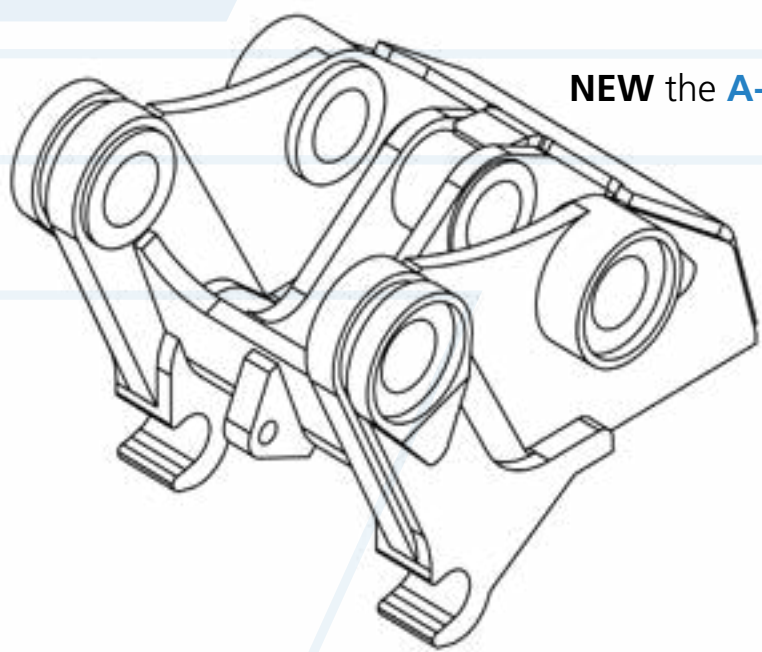

**NEW** the **A-Lock T5**



Quick coupler **A-Lock BB**

## Technical details (Subject to change)

Model	A-Lock BB	A-Lock 3 TU	A-Lock 3 Combi TU	A-Lock T-5
suitable for, examples	Blue Badger, mini Badger	yellow Fox, ECR145T, ITC312	LH R924, R930, R944 ECR235T	LH R950T, ECR355T
Excavator weight class, to.	< 12	12 - 24	24 - 40	> 40
Sealed excavator-connection possible	✓	✓	✓	✓
Number of claws	2	2	4	2
Locking version, standard	Safety	Compact / Bolt-cylinder	Compact / Bolt-cylinder	Safety
Operation by hand pump, option	✓	✓	✓	-
Mechanich version, option	-	✓	✓	-
Integrated load hook	-	✓	✓	-
Load eye for shackle, option	✓	-	-	✓
Rotation circuit connections integrated	-	✓	✓	-
Improved power transmission through separate pressure piece (bucket cylinder)	✓	✓ YF	-	✓



CERTIFICATION

## Your advantage and highest safety standards

- ✓ **SUVA-type examination certificate Nr. E 7264**
- ✓ **Form-fitting locking, no force-locking wedge connection**
- ✓ **Compact design**
- ✓ **Two-hand operation, acoustic und optical locking control**
- ✓ **Wear compensation** according to **spring bracket** on the **tool**
- ✓ **Long service life due to;**
  - Use of **wear-resistant special steels**
  - Use of **original WIMMER** attachment tools
  - **Professional regeneration** of the **quick coupler** by **WIMMER**
  - **Regeneration** of the **attachments simultaneously** with the **quick coupler regeneration**



WIMMER Hartstahl GmbH & Co KG und WIMMER Felstechnik GmbH  
Industriestraße 3 | A-5303 Thalgau, AUSTRIA | Tel. +43 (0)6235 6655-0  
All Rights and technical changes reserved. Copyrighted. Record and printing errors reserved. Status 10/25

>>> [back to the general overview](#)

[wimmer.info](#)

# Tunnel-attachment-tools XHD tunnel-driving-buckets / buckets

- Made entirely from special wear-resistant steels
- Tailor-made solution for every tunnel application
- More than 30 years of experience in the construction of tunnel buckets
- Equipped as standard with Esco Ultralock tooth system

Weblink  
buckets

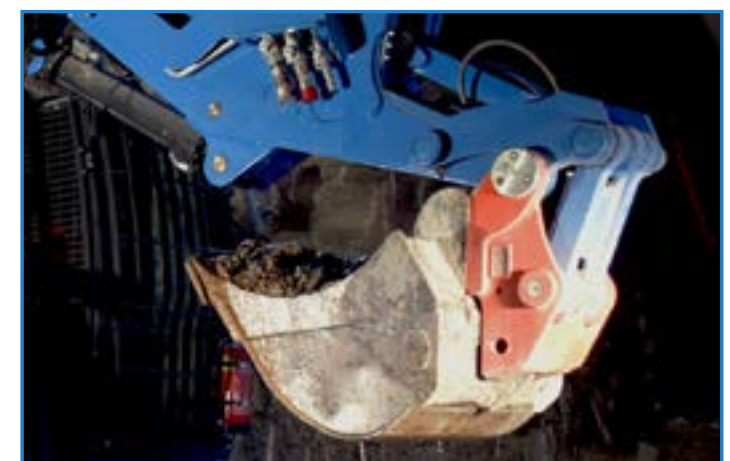

## Driving buckets - Technical details (Subject to change)

Model - Standard	LPT460	LPT600	LPT715/600	LPT725	LPT800
fitting on	Blue Badger	yellow Fox, ECR145T	LH R924, R930, ECR235T	LH R944T, R950T, ECR355T	LH R950T, ECR355T
Cutting width mm	460	600	715 or 600	725	800
Quick coupler, Standard	A-Lock-BB	A-Lock 3	A-Lock 3-Combi	A-Lock 3-Combi	A-Lock T5
Alternative quick coupler possible	✓	✓	✓	✓	✓
Shape can be individually adjusted	✓	✓	✓	✓	✓
Teeth	2x Esco U30 P	2x Esco U35 P	2x oder 3x Esco U45 P	2x oder 3x Esco U55 P	2x oder 3x Esco U55 P

## Examples of possible designs and shapes

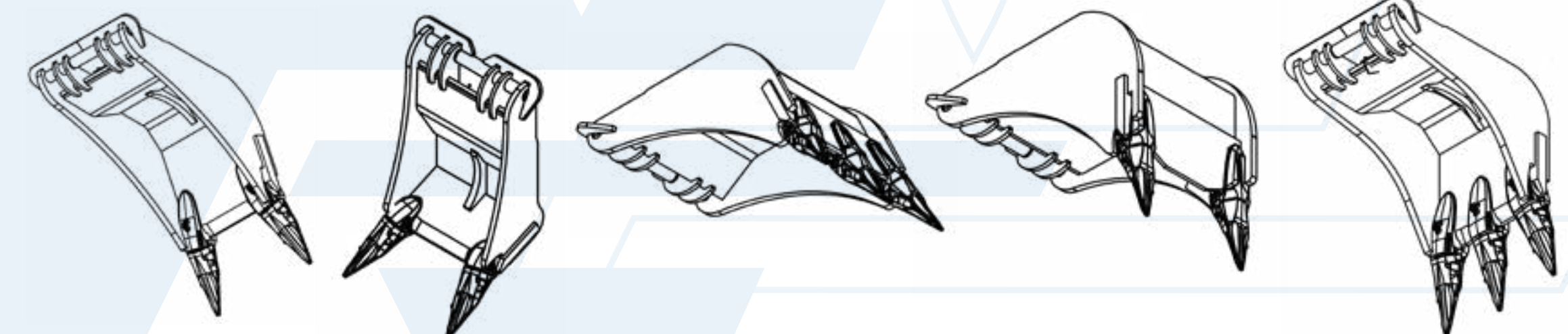

- ✓ Suitable for **tunneling**, **overlapping shape** for **overhead rework**
- ✓ **Special design** enables the **backing** in the **tunnel profile**
- ✓ The **design** determines the **possible working positions**
- ✓ **Individual solutions** according to **customer requirements**
- ✓ **Tooth position** **straight** or **slanted**

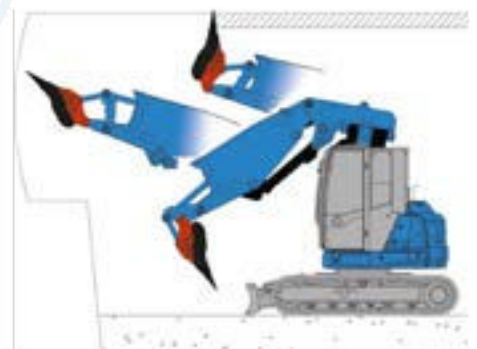
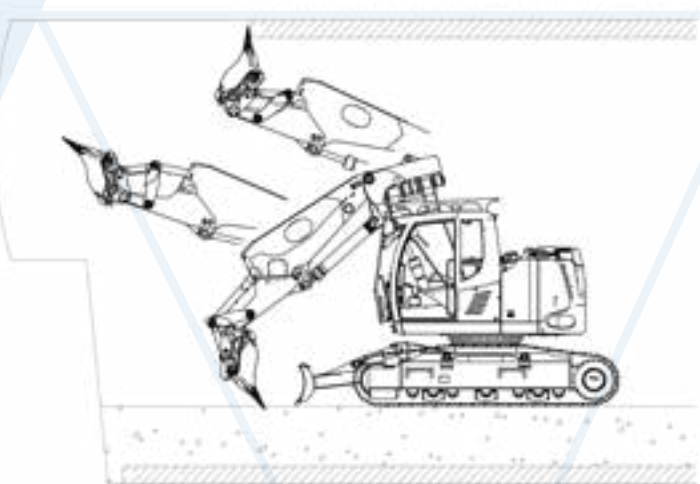

## XHD-bucket / loading bucket

- ✓ **Robust buckets** for **extreme operating conditions**
- ✓ **Standard design "Fels Geschwungen"**
- ✓ **Individual shapes** depending on **requirements**
- ✓ **A-Lock system**, **fixed bolted** or **mountable** according to **customer requirements**
- ✓ **Easily configurable** with the

[bucket-configurator >>>](#)



WIMMER Hartstahl GmbH & Co KG und WIMMER Felstechnik GmbH  
Industriestraße 3 | A-5303 Thalgau, AUSTRIA | Tel. +43 (0)6235 6655-0  
All Rights and technical changes reserved. Copyrighted. Record and printing errors reserved. Status 10/25



>>> [back to the general overview](#)

[wimmer.info](#)

# Tunnel-attachment-tools Hydraulic breaker WH TU/UW

- Standard series as underwater and tunnel version [Weblink WH TU/UW](#)
- Integrated central lubrication for reduced maintenance
- Three point-tool-bearing for low wear and precise impact
- Modern tunnel hydraulic breakers powered by WIMMER

## Technical details (Subject to change)

**ATTENTION: the hydraulic values indicated here after are not to be considered for the regulation of the excavator – please use the instructions!**

Model	WH 10 TU/UW	WH 17 TU/UW
Impact principle	Oil impact	Oil impact
Operating weight* kg	750	1.100
Oil flow, l/min	60 - 110	80 - 130
Working pressure, bar	125 - 130	135 - 140
Pressure relief valve, bar	190	200
Chisel ø, mm	95	115
Carrier weight, to	7 - 13	16 - 24
Fitting on	Blue (e) Badger, mini (e) Badger / ECR88T	yellow Fox / ECR145T
Underwater	✓	✓
Tunnel	✓	✓

Model	WH 22 TU/UW	WH 26 TU/UW	WH 29 TU/UW
Impact principle	Oil impact	Oil impact	Oil impact
Operating weight* kg	1.650	1.980	2.350
Oil flow, l/min	100 - 150	120 - 180	160 - 210
Working pressure, bar	135 - 140	135 - 140	140 - 145
Pressure relief valve, bar	200	200	210
Chisel ø, mm	125	135	145
Carrier weight, to	22 - 29	25 - 35	30 - 38
Fitting on	LH R924	LH R930 / ECR235T	LH R950, R944 / ECR355T
Underwater	✓	✓	✓
Tunnel	✓	✓	✓

- Oil-strike-principle with gas-pressure-accumulator for constant piston acceleration and impact energy
  - Three point-tool-bearing for low wear on the bushings - piston strike straight on the chisel
  - Hydraulic damping in addition to the blank firing protection prevent the hydraulic hammer and the excavator due damage
  - The hammer housing has a completely unique structure
  - Inclusive central lubrication
  - Tunnel-Version (TU):** Special tunnel sealing of the chisel / Higspeed piston with shortened stroke as additional protection
  - Underwater-Version (UW\*\*):** Prepared with separate connection for air supply in the area of the bushings and the piston
  - Combination of TU & UW\*\*:** Additional protection against the ingress of water, dirt and dust / Long service life
- \*\* An external air supply is required / Additional installations on request

WIMMER Hartstahl GmbH & Co KG und WIMMER Felstechnik GmbH  
Industriestraße 3 | A-5303 Thalgau, AUSTRIA | Tel. +43 (0)6235 6655-0

All Rights and technical changes reserved. Copyrighted. Record and printing errors reserved. Status 10/25

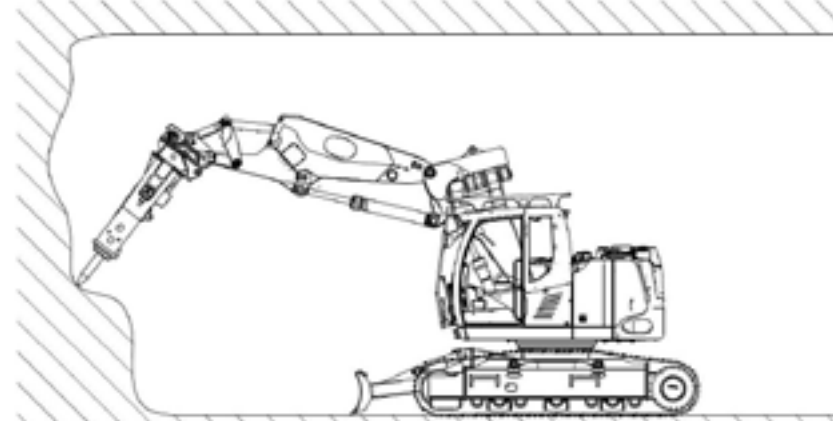
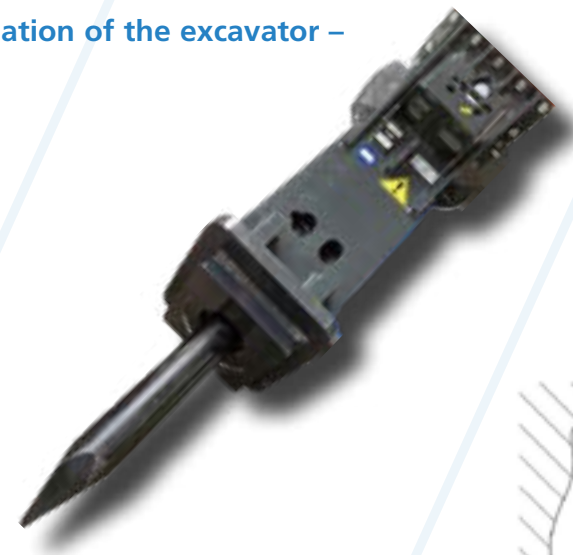

Breaker operation in tunnel use - example WH17 TU/UW on the yellow Fox



The NEW tunnel sealing

# WIMMER INTERNATIONAL



TU-breaker in action with the mini Badger



Central greasing pump - installation standard

For lubrication we recommend: WIMMER T-Grease



>>> back to the general overview

wimmer.info

# Tunnel-attachment-tools Hydraulic cutter Rockwheel

- For excavator sizes from 1 to. bis 70 to.
- Low vibration and noise
- Action radius: 360° with rotator (optional)
- Reduction of overhangs

## Technical details (Subject to change)

**ATTENTION: the hydraulic values indicated here after are not to be considered for the regulation of the excavator – please use the instructions!**

Model	C2	G5	G5 - twin	D10	D15
Excavator size, to	0.7 - 2.5	2,5 - 6	5 - 10	8 - 12	12 - 18
Hydraulic performance, kW	9,5	22	44	29	41
Operating weight, kg	66	181	200	426	595
Maximum pressure, bar	225	400	400	400	400
Working pressure	50 - 225	180 - 400	180 - 400	180 - 400	180 - 400
Maximum oil flow, l/min	60	65	100	112	132
Optimum oil flow, l/min	30	40	80	60	120
Transmission	1 : 1	2 : 1	2 : 1	1 : 1	1 : 1
Torque cutter, Nm @ bar	1.095 @ 225	4.429 @ 350	4.696 @ 350	4.173 @ 350	6.945 @ 350
Break force, kN @ bar	8 @ 225	26 @ 350	29 @ 350	19 @ 350	29 @ 350
Drum speed rpm @ l/min	98 @ 30	50 @ 40	95 @ 80	80 @ 60	96 @ 120
Number of chisel	46	32	32	56	64
Drum ø, mm	270	340	340	423	475
Drum width, mm	300	405	405	743	832
Length of the cutter	509	618	618	798	937

Model	D20	D30	G40	G50	G60
Excavator size, to	17 - 26	25 - 38	35 - 45	42 - 52	50 - 70
Hydraulic performance, kW	70	110	140	140	220
Operating weight, kg	1.170	1.444	1.662	2.458	2.478
Maximum pressure, bar	400	400	400	400	400
Working pressure	180 - 400	180 - 400	180 - 400	180 - 400	180 - 400
Maximum oil flow, l/min	320	460	540	540	680
Optimum oil flow, l/min	220	320	360	360	540
Transmission	1 : 1	1 : 1	1,3 : 1	1,2 : 1	1,2 : 1
Torque cutter, Nm @ bar	14.272 @ 350	23.362 @ 350	40.324 @ 350	37.833 @ 350	46.900 @ 350
Break force, kN @ bar	78 @ 220	76 @ 320	49,6 @ 360	52 @ 360	64 @ 540
Drum speed rpm @ l/min	48 @ 350	69 @ 350	118 @ 350	104 @ 350	129 @ 350
Number of chisel	64	60	54	56	56
Drum ø, mm	646	677	684	726	726
Drum width, mm	1.156	1.156	835	1.050	1.050
Length of the cutter	1.155	1.170	943	1.356	1.350

WIMMER Hartstahl GmbH & Co KG und WIMMER Felstechnik GmbH  
Industriestraße 3 | A-5303 Thalgau, AUSTRIA | Tel. +43 (0)6235 6655-0

All Rights and technical changes reserved. Copyrighted. Record and printing errors reserved. Status 2/26

# powered by ROCK.ZONE



>>>



# WIMMER INTERNATIONAL



Hydraulic cutter in tunneling

Option  
Cutter with 360° rotation  
endless turnable



Optionally, all types are also available with water spray unit for dust suppression



## Your benefits

- Avoiding microcracks
- Dust-free work according to built-in water spray device (optional)
- Milled material in gravel size
- Fatigue-free working
- Operating radius: 360° with rotator (optional)

to the product video >>>

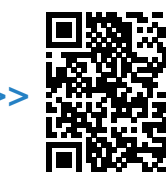

>>> back to the general overview

wimmer.info

# Tunnel-attachment-tools Tunnel arch gripper

- Custom-made special grippers for tunnel and lattice arches [Weblink TU Gripper](#)
- Optionally for tunnel arches (beams) or lattice arches
- Direct mounting or quick coupler mount
- Each gripper is custom-made for the respective tunnel profile

## Technical details (Subject to change)

ATTENTION: the hydraulic values indicated here after are not to be considered for the regulation of the excavator – please use the instructions!

Modell	GBG-180	WTG-180-Universal	GBG-270	WTG-270-Universal
Carrier	Blue Badger, mini Badger / ECR88	Blue Badger, mini Badger / ECR88	Yellow Fox, LH R924, 944, 950 / ECR145, 235, 355	Yellow Fox, LH R924, 944, 950 / ECR145, 235, 355
Tunnel arches   lattice arches	<b>3 belt H1: 70,95,115</b> <b>4 belt H1: 190</b>	TH70: 40-44, 34-36, 21, 25, 29, HEB 100, 120, 140, 160	<b>3 belt H1: 70,95,115</b> <b>4 belt H1: 190</b>	TH70: 40-44, 34-36, 21, 25, 29, HEB 100,120,140,160,180,200
Tilting funktion	2x45°	2x45°	2x45°	2x45°
Rotation	-	-	-	-
Remote controlled	-	-	-	-
Interchangeable gripping units	✓	-	✓	-
Universal gripping units	-	✓	-	✓
Voltage supply	12V oder 24V	12 V	24V	24V
<b>Hydraulic data</b>				
Pressure max., bar	200	200	200	200
Oil flow, l/min	15	15	25	25

Model	WTG-270-HEB220/240	WTG-226EC	WTG-30EC
Carrier	Yellow Fox, LH R924, 944, 950 / ECR145, 235, 355	LH R950 / ECR355T	LH R950 / ECR355T
Tunnel arches   lattice arches	HEB240, HEB220	HEB240, HEB220, HEB180, HEB160	H305UC
Tilting funktion	2x45°	2x40°	2x15°
Rotation	-	360°	2x15°
Remote controlled	-	✓	✓
Interchangeable gripping units	✓	✓	-
Universal gripping units	-	-	-
Voltage supply	24V	24V	24V
<b>Hydraulic data</b>			
Pressure max., bar	200	220	250
Oil flow, l/min	25	100	100

- ✓ Each gripper is a unique development and is tailored to the type of the tunnel profile as well as the size of the carrier device, max. load holding torque and the exact application.

WIMMER Hartstahl GmbH & Co KG und WIMMER Felstechnik GmbH  
Industriestraße 3 | A-5303 Thalgau, AUSTRIA | Tel. +43 (0)6235 6655-0

All Rights and technical changes reserved. Copyrighted. Record and printing errors reserved. Status 10/25



WTG-270  
Universal

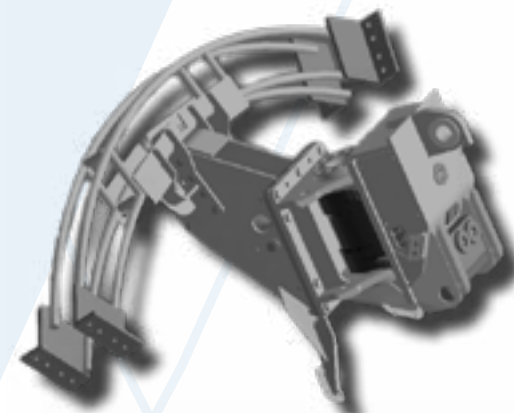
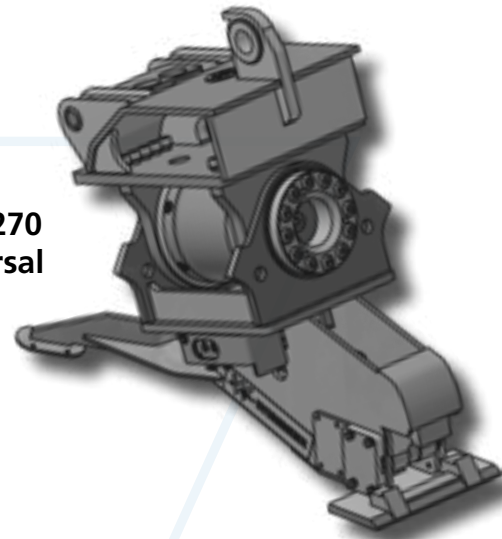

GBG-270

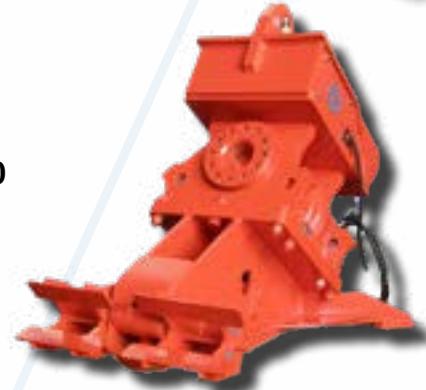

WTG-270  
HEB220/240



WTG-226EC



WTG-30EC

For lubrication we recommend:  
WIMMER PB-Grease



>>> [back to the general overview](#)

[wimmer.info](#)



# Tunnel-attachment-tools Demolition shears

- Universally applicable system shear [Weblink shears](#)
- Made entirely from special wear-resistant steels
- Hydraulically 360° endlessly rotatable
- For excavator sizes from 12 to 50 to.

## Technical details (Subject to change)

ATTENTION: the hydraulic values indicated here after are not to be considered for the regulation of the excavator – please use the instructions!

Model	Tunn-CUT 500 H	Top-CUT 550
Carrier	Blue Badger, mini Badger / ECR88	Yellow Fox, LH R924, ECR145
Possible jaws	H-Jaw (H)	Universal (U) Aligator (A) Scrap (S)
Max. Jaw opening, mm	500 (H)	550 (U) 740 (H) 470 (S)
Weight without adapter,, kg	1.340	1.885 (U) 1.835 (H) 1.835 (S)
Excavator weight, to.	> 12	> 16
<b>Hydraulic data</b>		
Open/close, max. pressure, bar	350	350
Open/close, oil flow, l/min	200	200
Rotate, max. pressure, bar	200	200
Rotate, oil flow, l/min	20 - 25	20 - 25

Model	Top-CUT 700	Top-CUT 800
Carrier	LH R930, R934 ECR235T	LH R944, R950 / ECR355T
Possible jaws	Universal (U) Aligator (A) Scrap (S)	Universal (U) Aligator (A) Scrap (S)
Max. Jaw opening, mm	2.250 (U) 2.480 (A) 2.200 (S)	3.300 (U) 3.170 (A) 3.170 (S)
Weight without adapter,, kg	2.250 (U) 2.480 (A) 2.200 (S)	3.300 (U) 3.170 (A) 3.170 (S)
Excavator weight, to.	> 20	> 25
<b>Hydraulic data</b>		
Open/close, max. pressure, bar	350	350
Open/close, oil flow, l/min	250	250
Rotate, max. pressure, bar	200	200
Rotate, oil flow, l/min	20 - 25	20 - 25

WIMMER Hartstahl GmbH & Co KG und WIMMER Felstechnik GmbH  
Industriestraße 3 | A-5303 Thalgau, AUSTRIA | Tel. +43 (0)6235 6655-0

All Rights and technical changes reserved. Copyrighted. Record and printing errors reserved. Status 10/25



Demolition shear Tunn-CUT 500 H



Top-CUT with Universal-jaw in action, material processing

## Shear / Jaw models

Universal (U)

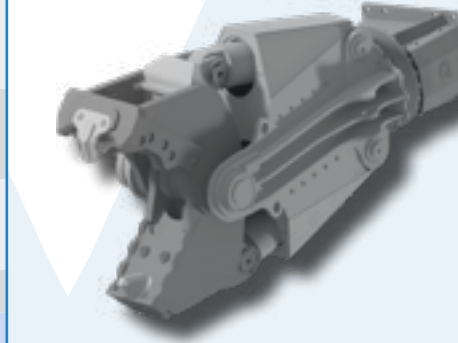

Aligator (A)

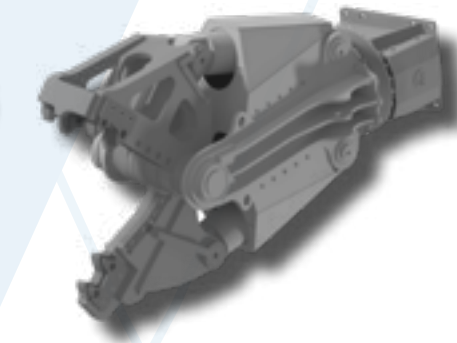

H-Jaw (H)

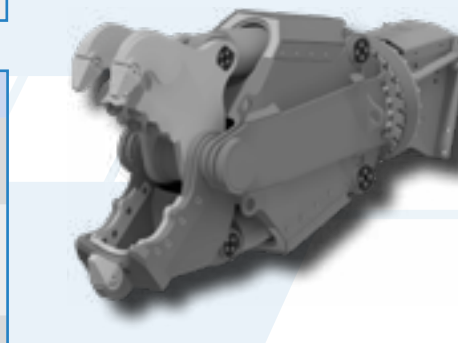

Scrap (S)

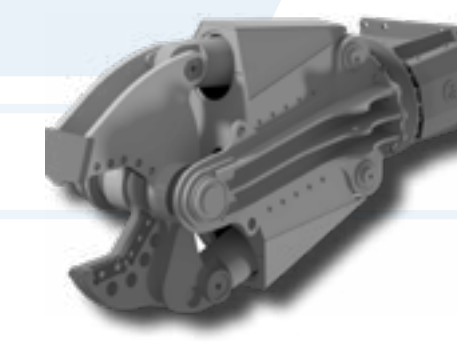

## WIMMER Abbruchzangen Anwendungen im Tunnel

- Demolition of elm tunnels and temporary structures
- Demolition of suspended ceilings during renovations
- For material processing, crusher preparation
- Steel scrap - cutting



>>> [back to the general overview](#)

[wimmer.info](#)

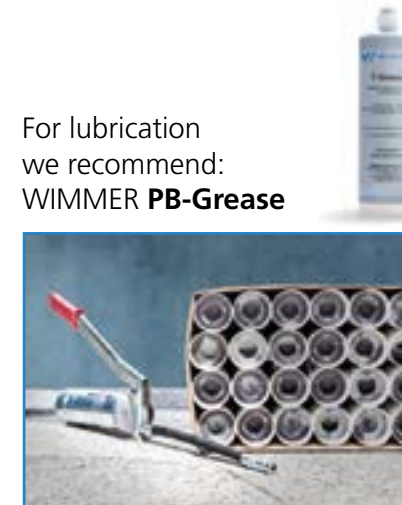

For lubrication we recommend:  
WIMMER PB-Grease

# Tunnel-attachment-tools Attachment drilling units

- Movement functions adapted to the tunnel Weblink drilling units
- Individually adapted to the respective product
- Robust – high-quality components for a long service life
- High level of standard equipment, many additional options

## Technical details (Subject to change)

**ATTENTION: the hydraulic values indicated here after are not to be considered for the regulation of the excavator – please use the instructions!**

Model - Drill and Split - WIDA	AB C20 T-4
Drill hammer	WD8
Torque max., Nm	400
Carriage type	CF310
DARDA splitting cylinder	C20 N / L
Effective splitting force, to, N / L	1.500 / 1.800
Drill depth min., mm, N / L	750 / 950
Carriage tilting	90°
Carriage rotation	360° not endless
Standard clamp	CF200
Integrated alternator	✓
Remote controlled	✓
Blank firing protection	✓
Anti-jamming automation, hollow protection	✓
Hose roller	-
Telescope version	-
Splitting cylinder positioning	Swing in
Application / Shank adapter	
Drill & split / Drill Ø, mm	76
Standard drill rod, shank adapter	R32, T38
Possible features / Options	
Angle indication	✓ (standard)
PLC-Automatic with depth measurement	✓ (standard)
Wimmer Cockpit	✓
Suction foot	✓
Requirements for the carrier device	
Carrier weight, to.	> 15
Required engine performance, kW	40
Oil supply (L / min)	120 @ 160 bar
Pressure max. relief valve (bar)	220
Dimensions and weight	
Weight without adapter, kg.	1.730
Length, mm	3.155
Drill rod length, mm	1.500
Mast feed, mm	650

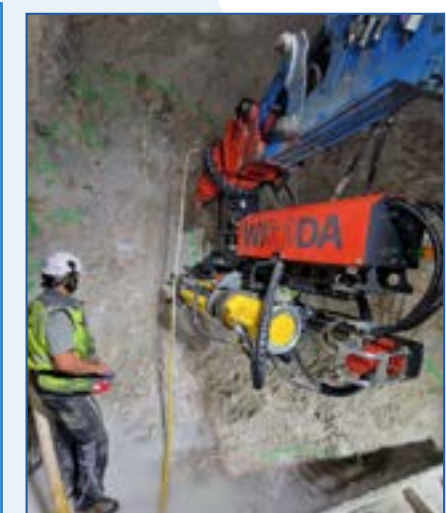

Tunnel-application WIDA AB C20 T-4

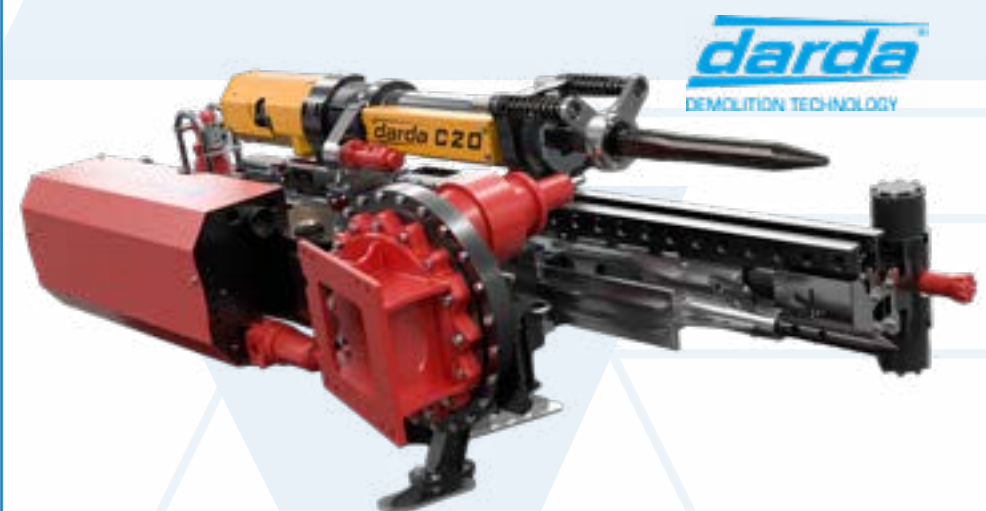

<<< Product video **WIDA**



Remote control model T6



WIMMER offers a wide range of drilling rig attachments. For the complete selection, see the "AB\_Gesamtübersicht" Don't have one yet? [Then request now >>>](#)



Model - Standard drilling unit TU	AB 1300 T	AB 2300 T
Drill hammer	WD8 / WD8-23   18   14 RH2X	WD8 / WD8-23   18   14 RH2X
Carriage type	CF310	CF300
Carriage tilting	90°	90°
Carriage rotation	360° not endless	360° endless
Standard clamp, single	CF200	CF200
Integrated alternator	✓	✓
Remote controlled	✓	✓
Blank firing protection	✓	✓
Anti-jamming automation, hollow protection	✓	✓
Hose roller	-	✓
Application / Shank adapter		
Drill and blast	✓	✓
Anchor drilling	✓	✓
DTH - drilling / overburden drilling	-	✓
Possible features / Options		
Angle indication	✓	✓
PLC-Automatic with depth measurement	✓	✓
Wimmer Cockpit	✓	✓
Possible clamp	CF200/Ø 135mm	CF200/Ø 135,160mm
Clamp-/ breaking device, double clamp	✓	✓
Suction foot	✓	✓
1-rod rod changer	-	✓
3-rod rod changer	-	✓
Requirements for the carrier device		
Carrier weight, to.	> 8	> 10
Dimensions and weight		
Weight, kg.	1.000	1.400
Length, mm	3.500	3.500



Movement options attachment-drilling-units with the T-model in the tunnel

# Service by WIMMER in tunneling

- Custom-made special solutions for your tunnel construction project Weblink contact
- Support and advice in planning and implementation
- Follow-up support from our field staff and technicians
- Fast response times for spare parts, service and repairs

## "Fast and comprehensive service" what we offer...

- ✓ Repairs of all kinds
- ✓ Professional maintenance by trained specialists
- ✓ Flexible and fast help
- ✓ Maximum operational reliability through the use of original parts
- ✓ Spare parts replacement on site by expert technicians
- ✓ Checking the settings on the carrier device
- ✓ Every service with a guarantee
- ✓ Comprehensive range of services
- ✓ Training and induction by our on-site experts
- ✓ International network of sales partners and suppliers
- ✓ Commissioning on site
- ✓ Initial and follow-up training regarding application, operation, maintenance and service



Special solution: Work basket in combination with lattice arch grab

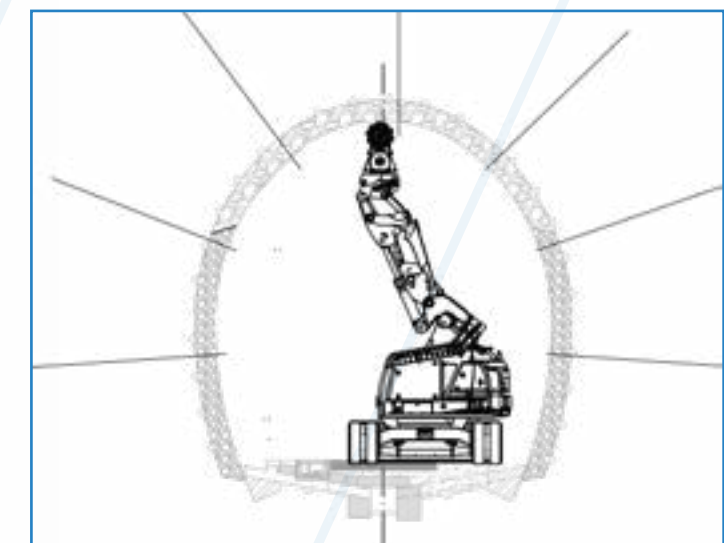

Schema mini Badger with cutter in profile



Quick coupler installation on site by our fitters and service technicians



Tunnel-construction-technician-training at ZaB/Eisernerz on the yellow Fox

## Comprehensive advice and support in the form of...

- Representation of our devices in the tunnel profile
- Creation of drawings and representations in 2D and 3D
- Comprehensive consulting regarding the use of our equipment for your project
- Development of complete solutions
- More than 40 years of experience in tunnel construction
- Development of special solutions
- Comprehensive training on tunnel excavators and attachments



WIMMER Hartstahl GmbH & Co KG und WIMMER Felstechnik GmbH Industriestraße 3 | A-5303 Thalgau, AUSTRIA | Tel. +43 (0)6235 6655-0

All Rights and technical changes reserved. Copyrighted. Record and printing errors reserved. Status 10/25

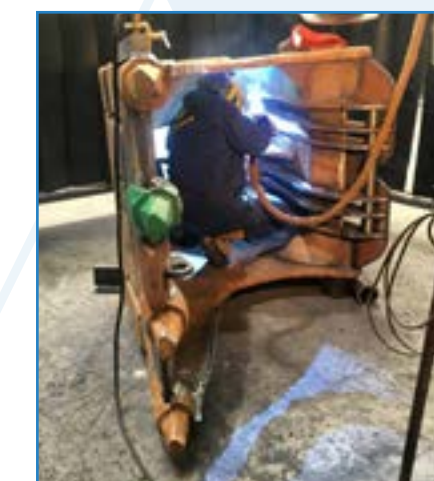

>>> back to the general overview

wimmer.info

>>> back to the general overview

wimmer.info

